

2

1

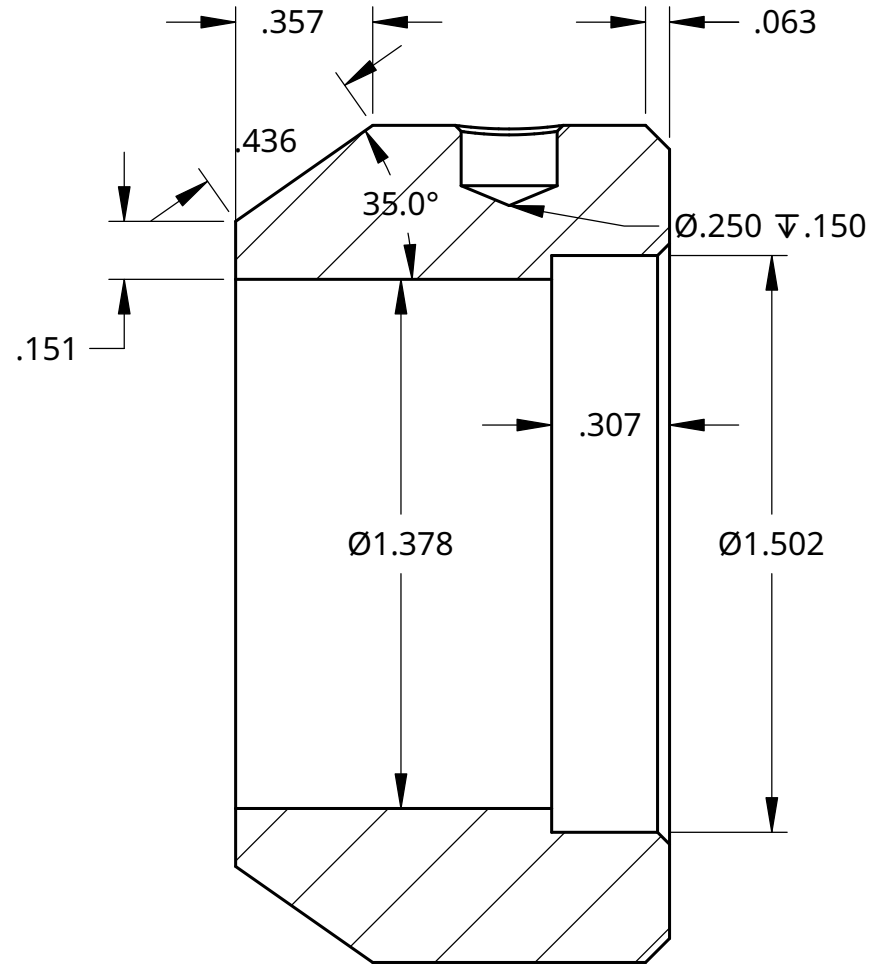
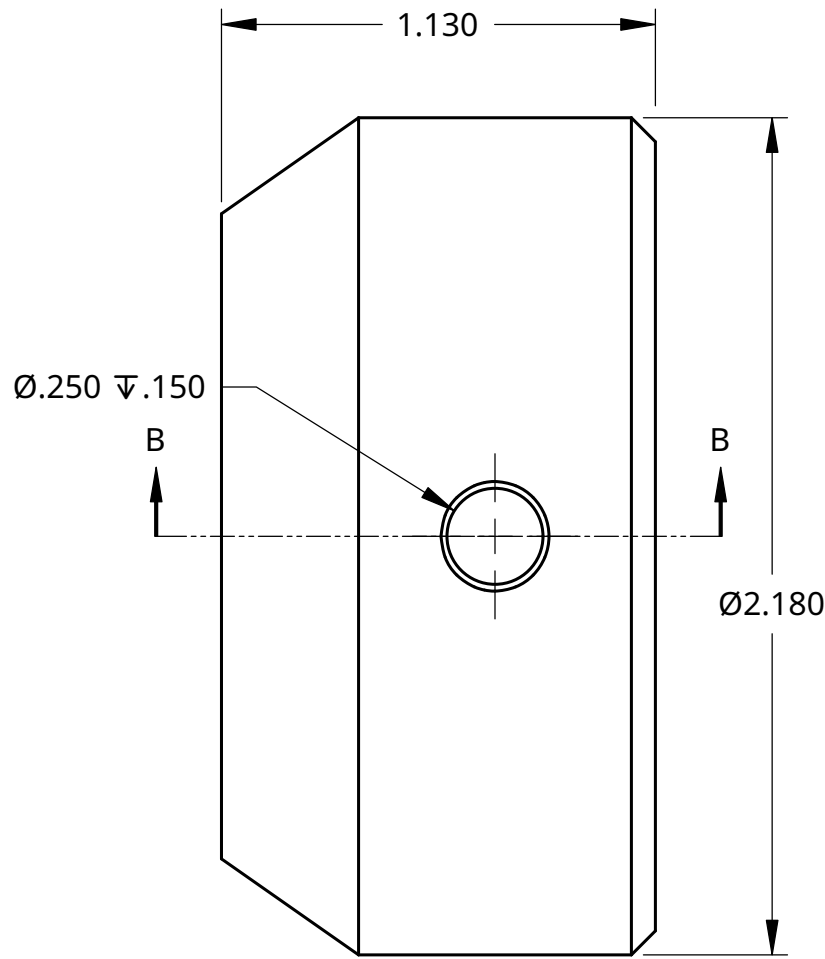

SCALE 2:1

SECTION B - B  
SCALE 2:1

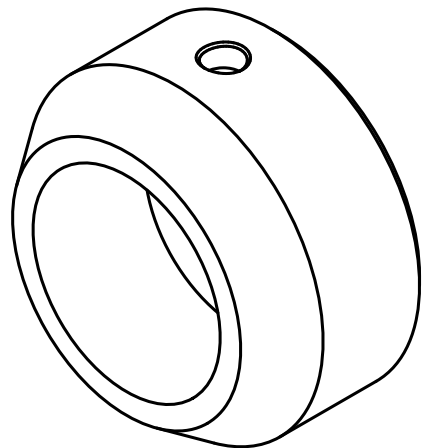

Thread 1 1/8-8 2A  
 1.365-1.390 min  
 1.419-1.428 pitch D  
 1.500 maj

UNLESS OTHERWISE SPECIFIED,  
 DIMENSIONS ARE IN INCHES

.XX = ±.0-  
 .XXX = ±.00-  
 .XXXX = ±.000-  
 ANGULAR = ± °  
 FRACTIONAL = ±

SURFACE FINISH

DO NOT SCALE DRAWING

BREAK ALL SHARP EDGES AND  
 REMOVE BURRS

THIRD ANGLE PROJECTION



	NAME	DATE
DRAWN	JJ BB	06/04/2024
CHECKED		
APPROVED		
MATERIAL	FINISH	

TITLE		
SIZE	DWG NO.	REV.
A		
SCALE	WEIGHT	SHEET
1:1		1 of 2

2

1

2

1

B

B

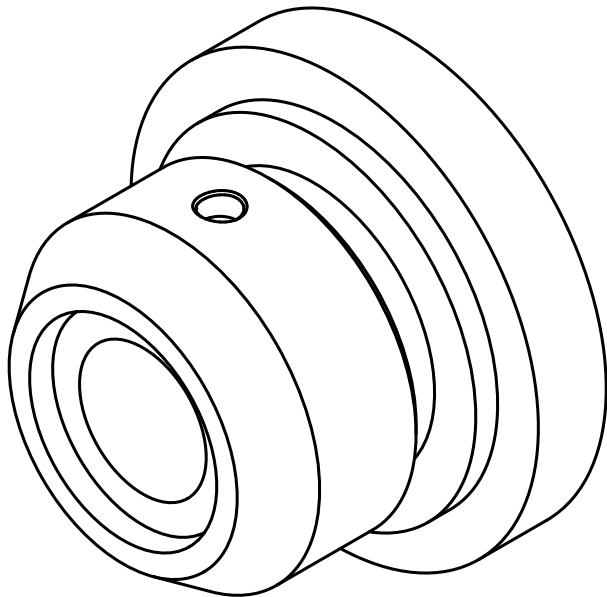

A

A

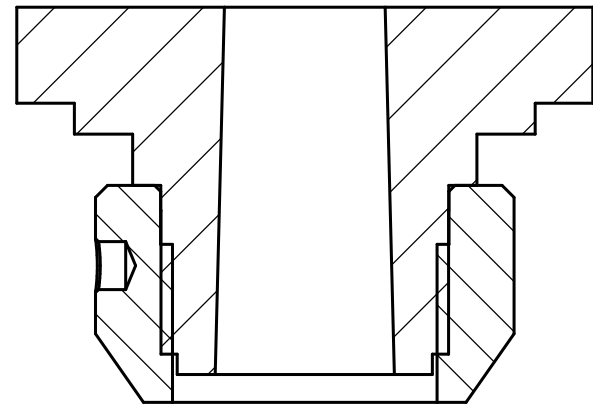
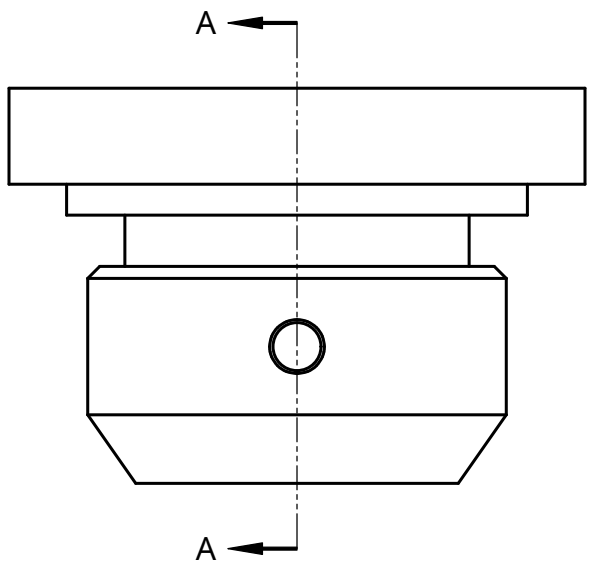

SECTION A - A

2

1

DWG NO.	SIZE A	SCALE 1:1	SHEET 2 of 2	REV.
---------	--------	-----------	--------------	------